

MAXITOP – LW C

Leakage detection probe



MAXITOP - LW C ZD

MAXITOP - LW C ZK

INSTRUCTIONS MANUAL

BAMO MESURES

22, Rue de la Voie des Bans - 95 100 ARGENTEUIL - FRANCE

Phone +33 (0)1 30 25 83 20 - E-mail: info@bamo.fr

Fax: +33 (0)1 34 10 16 05 - <http://www.bamo.eu>

Leakage detection probe
MAXITOP – LW C

MES

556-03

ac 11

CAUTION

Only trained personnel may perform installation, initial start-up and maintenance.

All applicable European and national regulations regarding installation of electrical equipment must be adhered to.

- The device may only be connected to supply power complying with the specifications included in the technical data and on the serial plate.

- The device must be disconnected from all sources of power during installation and maintenance work.

- The device may only be operated under the conditions specified in the operating instructions.

DESCRIPTION

The leakage detection probe MAXITOP LW C is used as a monitoring device for permanently installed containers used for the storage of non-flammable, water endangering liquids.

The MAXIMAT LW C has 5 different possible connections:

- Low voltage contact output (max. 50 V AC/DC, max. 0.5 A, max. 10 VA)
- Relay output to use with a CST device (data sheet 555-09)
- Relay output to use with a SHR relay (data sheet 555-06)
- Direct connection to a PLC
- Direct connection to an alarming unit TC4 (data sheet 555-07)

Applications: Note that stored liquids may not tend to precipitate insulating or conductive sediments.

CE mark: In accordance with low-voltage directive (2006/95/CE), EMC directive (89/336/EWG).

TECHNICAL FEATURES

Power supply:	15 ... 26 V DC (when a fuse 250 mA is installed)
Power consumption:	< 1 W
Ambient temperature:	-20 to +60°C
Operating pressure:	atmospheric (0.8 to 1.1 bar)
Alarming:	5 mm immersion depth as a minimum
Hysteresis:	Approx. 2 mm
Probe:	PEHD
Terminal housing:	PBT, fibre glass reinforced, IP 65 acc. EN 60 529
Terminals:	Screw connectors, IP 20; max. wire cross-section 2.5 mm ² (300 m long cable as a maximum)
Input:	For an external push in switch to run a test sequence; T & C connectors
Status display:	1 LED (green) inside the terminal housing; lighting = perfect conditions; Off = or alarm status or error status

WIRING POSSIBILITIES



2 wires cable symbol



3 wires cable symbol

Using a TC4 signalling device

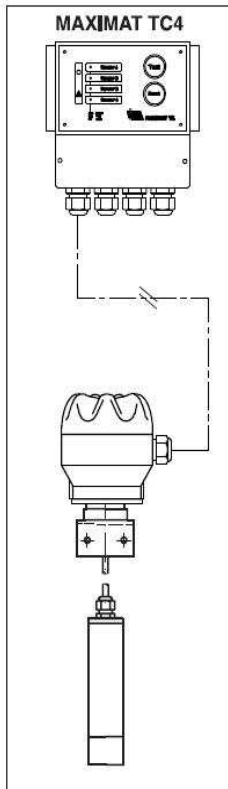

Using a PLC

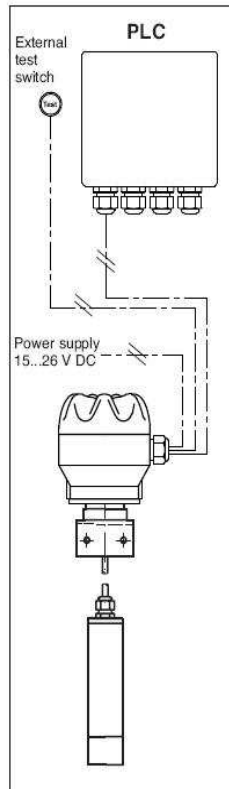

Using a relay SHR

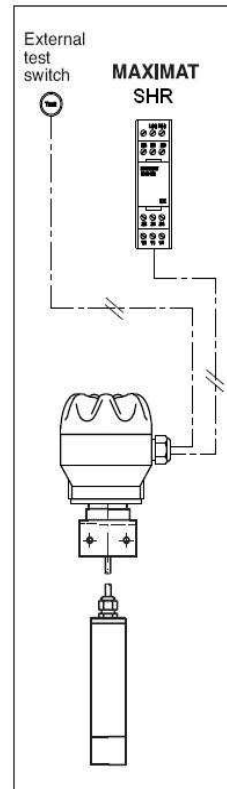

Using a relay CST

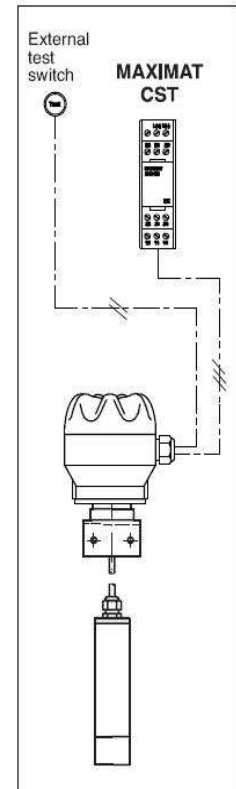

NOTE: The external test push button is useful for a diagnostic of the system. It is not necessary for the proper detection mode.

INSTALLATION

The leakage sensor's probe is suspended such that it hangs into the catch basin of the storage tank to be monitored.

The probe may make contact with the outside wall of the catch basin, or may stand on its floor.

The cable must be secured such that the probe is always positioned vertically.

The connector cable between the probe and the measuring transducer is pulled through the Pg fitting mounted to the bracket or the cap until the portion of the cable inside the catch basin holds the probe in the vertical position.

When installed in a free-hanging manner, it must be assured that the connector cable is only pulled far enough through the adjustor fitting to allow for a maximum clearance of 45 mm between the probe and the catch basin floor, so that the leakage alarm is triggered at a maximum fill-level of 50 mm.

MOUNTING EXAMPLES

a) Sensor's probe in contact with the catch basin floor

If the bottom of the sensor's probe is in contact with the floor of the catch basin, the alarm signal is triggered when the liquid reaches a fill-level of approximately 5 mm.

a. Sensor's probe above the catch basin floor

The sensor's probe is installed at 45 mm above the floor such that the alarm signal is triggered at a fill-level of 50 mm.

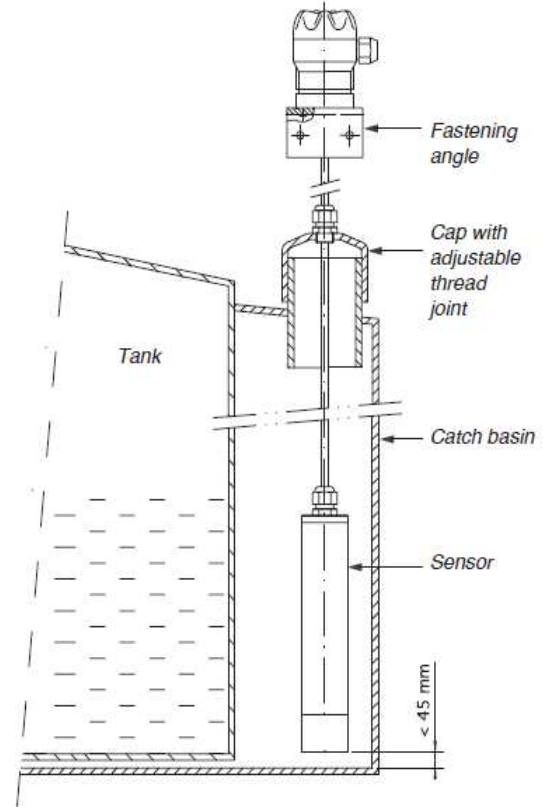

PERIODIC TESTING

The leakage probe must be tested for correct functioning at reasonable intervals, although not less than once a year. It is the sole responsibility of the user to select the utilised test type, as well as a testing interval within the prescribed timeframe.

Testing must be performed which substantiates flawless functioning of the leakage sensor, and correct interaction with all other associated components. This is assured by means of suitable simulation of a leak, or the physically measured effect which causes triggering of the alarm signal. If correct functioning of the leakage sensor can be established by other means (exclusion of function impairing errors), testing can be executed by simulating the appropriate output signal.

COMPONENT MATERIAL

Verify the chemical compatibility of probe materials with existing fluids.

MAXITOP LW C

Component	Material
Probe	PE-HD (polyethylene)
Measuring cable	PVC (polyvinyl chloride)
Cap dia.63 mm (...CZD)	PVC (polyvinyl chloride)
Bracket	PVC (polyvinyl chloride)
Pg fitting	PA (polyamide)
Seal / Pg fitting	NBR (perbunan)

WIRING

Power supply input 15 ... 26 V DC

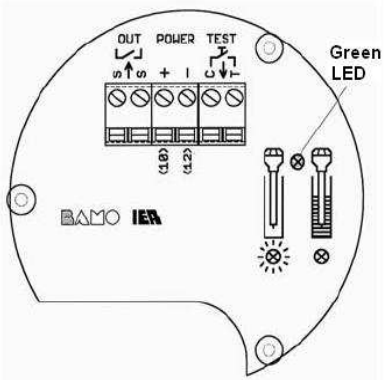

Built-in contact (Reed contact)

(Reed contact)

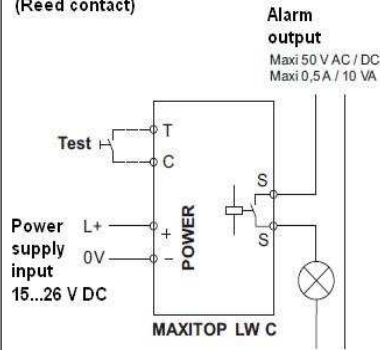

PLC

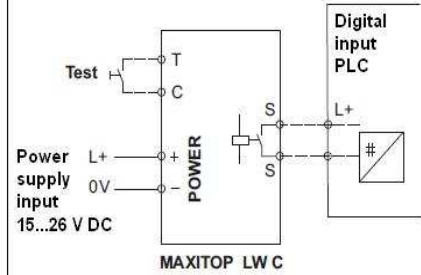

CST Relay

Main power 230 V / 50 Hz

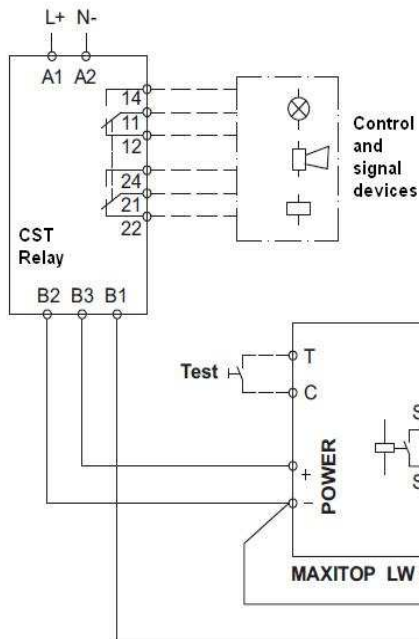

SHR Relay

Main power 230 V / 50 Hz

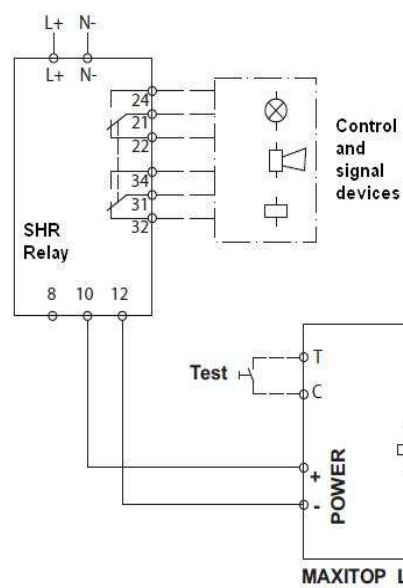

TC4 Programming, outputs, etc. please report to TC4 manual

Main power 230 V / 50 Hz

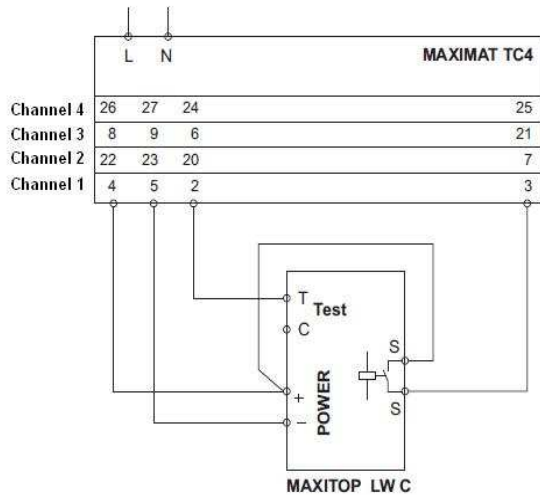

LED AND CONTACT STATUS

Power off
LED off
Opened contact

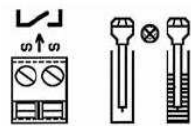

Normal survey status
Closed contact
LED lighting



Alarm, leakage detection
Opened contact
Led off

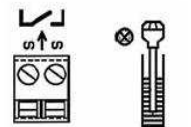

TEST INSTRUCTIONS FOR OVERFILLING AND LEAKAGE DETECTION PROBES

Measuring Method

The measuring sensor works in accordance with the capacitive proximity switch principle. In this application the non-conductive medium –air- changes to a conductive medium –stored chemical- when an overflowing or a leakage occurs.

Applications

The measuring sensors are suitable to liquids for which **reactive impedance is less than 5 kOhm/cm**, or with a **coupling capacitance to earth is greater than 50 pF**. Stored liquids may not tend to precipitate insulating or conductive sediments.

Periodic testing

The frequency for testing the complete system should be at least once a year, or more often, and in any case according to the rules of the Country where is the installation.

Proceed to a test before the installation and initial start-up.

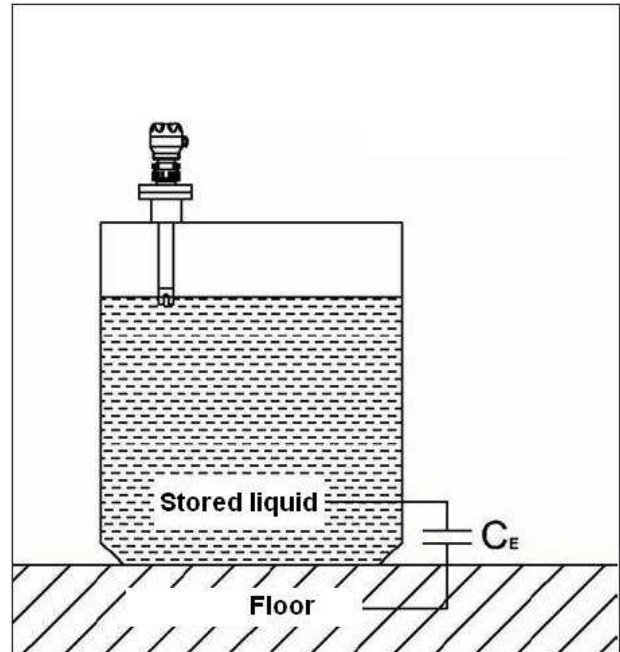

Test method

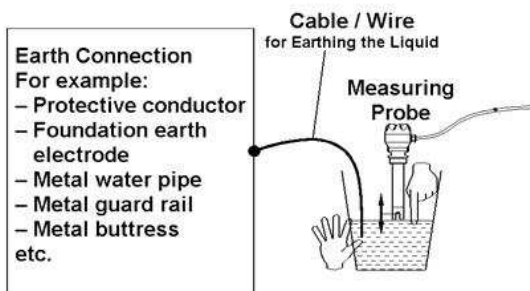

The bucket may not touch the floor

- Fill a bucket (plastic or metal) with original liquid or water (at least 5 litres).
- Earth the liquid in the bucket with a cable/wire.
or
Grasp the bucket with your hand from the outside.
or
Immerse a finger into the liquid.
- At the same time, immerse and remove the measuring probe several times.
- Examine the switching status of the measuring circuit (refer to the respective operating instructions to this end).