

## Introduction

This installation guide provides instructions for installation, startup, and adjustment. To receive a copy of the instruction manual, contact your local Fisher Sales Office or Sales Representative or view a copy at [www.emersonprocess.com/regulators](http://www.emersonprocess.com/regulators). For further information refer to:

Type SR5 instruction manual (form 5786, D103099X012).

## P.E.D. Categories

This product may be used as a pressure accessory with pressure equipment in the following Pressure Equipment Directive 97/23/ EC categories. It may also be used outside of the Pressure Equipment Directive using sound engineering practice (SEP) per table below.

PRODUCT SIZE	CATEGORIES	FLUID TYPE
DN 15, 20, and 25 (1/2 thru 1-inch)	SEP	1
DN 40 x 25, 40, and 50 (1-1/2 x 1, 1-1/2, and 2-inch)	I	
DN 80 (3-inch)	II	

## Specifications

### Available Constructions

**Type SR5:** Pressure reducing regulator designed for use in sanitary applications. DN 15, 20, 25, 40 x 25, 50, and 80 (1/2, 3/4, 1, 1-1/2 x 1, 2, and 3-inch) body sizes are suitable for controlling steam, liquids and gasses. DN 40 (1-1/2-inch) is suitable for steam and gasses, it is not for use on liquids. End connections match up to Tri-Clamp® sanitary fittings.

### Maximum Inlet and Outlet Pressures<sup>(1)</sup>

#### DN 15 to 40 (1/2 to 1-1/2-inch):

14,5 bar at 65 °C (210 psig at 150 °F)  
12,4 bar at 135 °C (180 psig at 275 °F)  
11 bar at 204 °C (160 psig at 400 °F)

#### DN 50 and 80 (2 and 3-inch):

*Maximum Inlet Pressure:*  
14,5 bar at 65 °C (210 psig at 150 °F)  
12,4 bar at 135 °C (180 psig at 275 °F)  
11 bar at 204 °C (160 psig at 400 °F)

#### Maximum Outlet Pressure:

10,3 bar at 65 °C (150 psig at 150 °F)  
8,62 bar at 135 °C (125 psig at 275 °F)  
7,58 bar at 204 °C (110 psig at 400 °F)

### Proof Test Pressure

All Pressure Retaining Components have been proof tested per Directive 97/23/EC - Annex 1, Section 7.4

### Outlet Pressure Ranges<sup>(1)</sup>

**DN 15, 20, 25 and 40 x 25 (1/2, 3/4, 1 and 1-1/2 x 1-inch):** 0,2 to 0,5 bar (2 to 8 psig), 0,4 to 1,7 bar (5 to 25 psig), 0,7 to 3,4 bar (10 to 50 psig), 1,7 to 6,2 bar (25 to 90 psig), and 2,4 to 9,3 bar (35 to 135 psig)

**DN 40 (1-1/2-inch):** 0,4 to 1,7 bar (5 to 25 psig), 0,7 to 3,4 bar (10 to 50 psig), 1,7 to 5,2 bar (25 to 75 psig), and 2,4 to 6,9 bar (35 to 100 psig)

**DN 50 and 80 (2 and 3-inch):** 0,7 to 1,7 bar (10 to 25 psig), 1,0 to 3,4 bar (15 to 50 psig) and 1,7 to 5,2 bar (25 to 75 psig)

### Temperature Capabilities<sup>(1)</sup>

#### Metal Seat (316L SST)

*Ethylene propylene (EPDM) Diaphragm and O-ring:*  
-28 to 135 °C (-20 to 275 °F)  
*316L SST Diaphragm and PTFE/FKM O-ring:*  
-6 to 204 °C (20 to 400 °F)  
*PTFE/FKM Diaphragm and O-ring:*  
-6 to 204 °C (20 to 400 °F)

#### Soft Seat (PTFE/316L SST)

*Ethylene propylene (EPDM) Diaphragm and O-ring:*  
-28 to 65 °C (-20 to 150 °F)  
*316L SST Diaphragm and PTFE/FKM O-ring:*  
-6 to 65 °C (20 to 150 °F)  
*PTFE/FKM Diaphragm and O-ring:*  
-6 to 65 °C (20 to 150 °F)

#### PEEK Seat (PEEK/316L SST)

*Ethylene propylene (EPDM) Diaphragm and O-ring:*  
-28 to 135 °C (-20 to 275 °F)  
*316L SST Diaphragm and PTFE/FKM O-ring:*  
-6 to 204 °C (20 to 400 °F)  
*PTFE/FKM Diaphragm and O-ring:*  
-6 to 204 °C (20 to 400 °F)

1. The pressure/temperature limits in this installation guide and any applicable standard or code limitation should not be exceeded.



## Installation



### WARNING

Only qualified personnel should install or service a regulator. Regulators should be installed, operated, and maintained in accordance with international and applicable codes and regulations, and Fisher instructions.

If the regulator vents fluid or a leak develops in the system, it indicates that service is required. Failure to take the regulator out of service immediately may create a hazardous condition.

Personal injury, equipment damage, or leakage due to escaping fluid or bursting of pressure-containing parts may result if this regulator is overpressured or is installed where service conditions could exceed the limits given in the Specifications section, or where conditions exceed any ratings of the adjacent piping or piping connections.

To avoid such injury or damage, provide pressure-relieving or pressure-limiting devices (as required by the appropriate code, regulation, or standard) to prevent service conditions from exceeding limits.

Additionally, physical damage to the regulator could result in personal injury and property damage due to escaping fluid. To avoid such injury and damage, install the regulator in a safe location.

Clean out all pipelines before installation of the regulator and check to be sure the regulator has not been damaged or has collected foreign material during shipping. Use suitable line gaskets and approved piping and bolting practices. Install the regulator in any position desired. However, to ensure self-draining (from outlet to inlet) the regulator should be installed with the spring case in the upright vertical position. The arrow on the body indicates flow direction.

### Note

**It is important that the regulator be installed so that the vent hole in the spring case is unobstructed at all times.**

## Overpressure Protection

The recommended pressure limitations are stamped on the regulator nameplate. Some type of overpressure protection is needed if the actual inlet pressure exceeds the maximum operating outlet pressure rating. Overpressure protection should also be provided if the regulator inlet pressure is greater than the safe working pressure of the downstream equipment.

Regulator operation below the maximum pressure limitations does not preclude the possibility of damage from external sources or debris in the line. The regulator should be inspected for damage after any overpressure condition.

## Startup

The regulator is factory set at approximately the midpoint of the spring range or the pressure requested, so an initial adjustment may be required to give the desired results. **Make sure the CIP/SIP Pin (key 30, Figure 1) is not installed in the spring case.** With proper installation completed and relief valves properly adjusted, slowly open the upstream and downstream shutoff valves.



### WARNING

**The CIP/SIP pin must be removed before regulator is placed in operation. The pin will inhibit the proper operation and function of the regulator and result in overpressure of the downstream system.**

## Adjustment

To change the outlet pressure, remove the closing cap or loosen the locknut and turn the adjusting screw or handwheel clockwise to increase outlet pressure or counterclockwise to decrease pressure. Monitor the outlet pressure with a test gauge during the adjustment. Replace the closing cap or tighten the locknut to maintain the desired setting.

## Pressure Loaded Construction

The spring case can be pressure loaded to adjust outlet pressure. An optional tapped spring case, guide ring seal and sealing washer on the adjusting screw must be used for these applications. The loading pressure is connected to the 1/4-inch NPT connection in the spring case allowing registration on the spring side of the diaphragm. Adjusting loading pressure will proportionally change the outlet pressure setting of the regulator. A small amount of mechanical spring load, in addition to the pressure load, is recommended. Regulator set pressure achieved from the combination of spring load and pressure load should not exceed the outlet pressure ranges listed on page 1.

## Taking Out of Service (Shutdown)



### WARNING

**To avoid personal injury resulting from sudden release of pressure, isolate the regulator from all pressure before attempting disassembly. Relieve all spring compression and isolate regulator from the pressurized system prior to removing the clamp (key 15, Figure 1).**

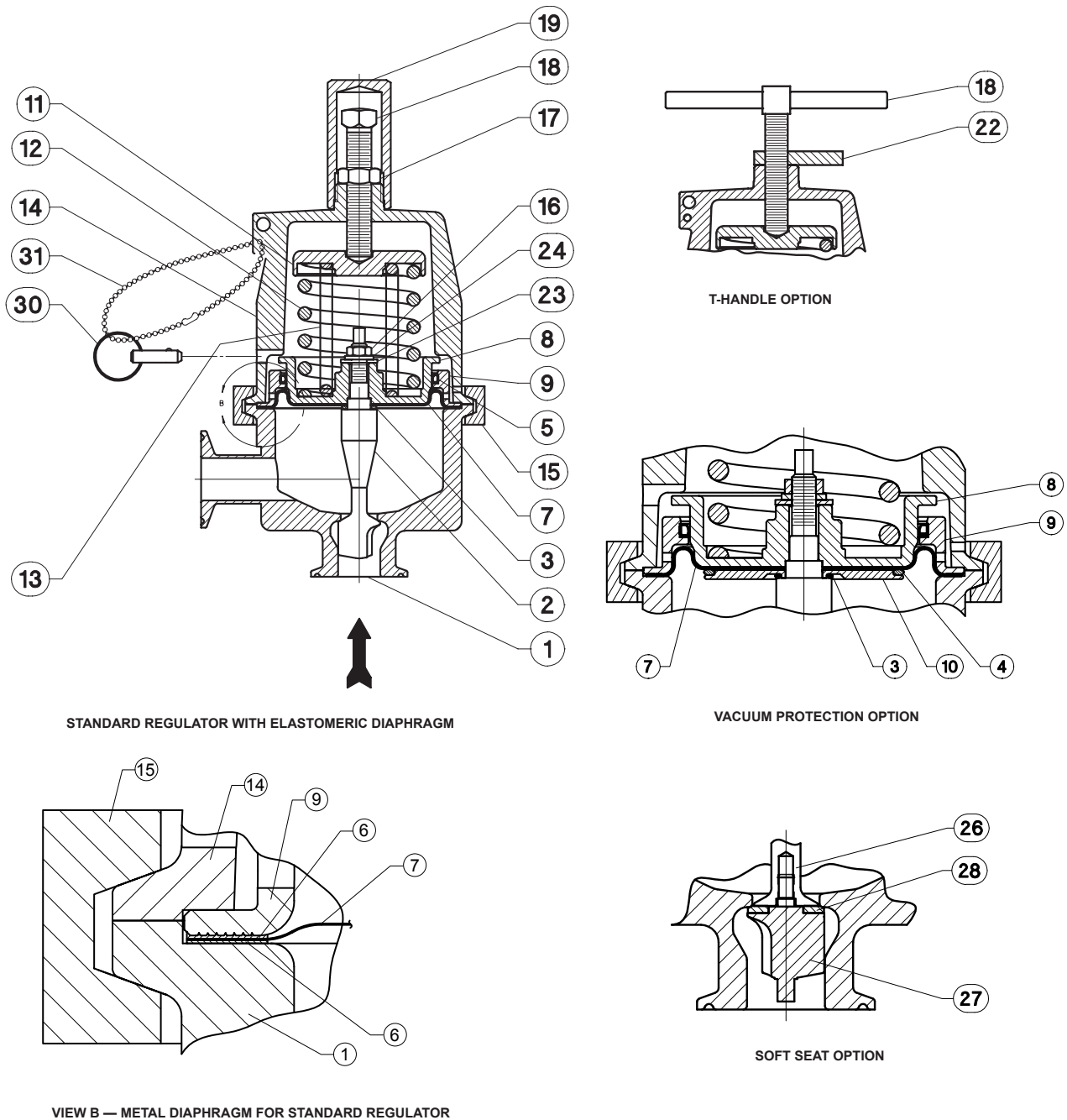

Figure 1. Type SR5 Sanitary Regulator Assembly

## Parts List

**Key Description**

1	Body
2	Plug (metal seat)
3	Plug O-Ring
4	Diaphragm Plate O-Ring
5	Piston Ring
6	Diaphragm Gasket
7	Diaphragm
8	Lower Spring Seat
9	Guide Ring
10	Diaphragm Plate
11	Upper Spring Seat
12	Spring
13	Inner Spring
14	Spring Case

**Key Description**

15	Bolted Clamp
16	Hex Nut
17	Hex Nut
18	Adjusting Screw
19	Closing Cap
22	Locking Lever
23	Flat Washer
24	Lock Washer
26	Upper Plug
27	Lower Plug
28	Soft Seat
30	Ring Grip Pin
31	Bead Chain

# Type SR5

---

## **Industrial**

USA - Headquarters  
McKinney, Texas 75070 USA  
Tel: 1-800-558-5856  
Outside U.S. 1-469-293-4201

Asia-Pacific  
Shanghai, China 201206  
Tel: 86-21-5899 7887

Europe  
Bologna, Italy 40013  
Tel: 39 051 4190611

## **Natural Gas Technologies**

USA - Headquarters  
McKinney, Texas 75070  
Tel: 1-800-558-5856  
Outside U.S. 1-469-293-4201

Asia-Pacific  
Singapore, Singapore 128461  
Tel: +65 6777 8211

Europe  
Bologna, Italy 40013  
Tel: 39 051 4190611  
Gallardon, France 28320  
Tel: +33 (0)2 37 33 47 00

## **Industrial/High Purity**

TESCOM  
Elk River, Minnesota 55330 USA  
Tel: 1-763-241-3238  
Selmsdorf, Germany 23923  
Tel: +49 (0) 38823 31 0

For further information visit [www.emersonprocess.com/regulators](http://www.emersonprocess.com/regulators)

The Emerson logo is a trademark and service mark of Emerson Electric Co. All other marks are the property of their prospective owners. Fisher is a mark owned by Fisher Controls, Inc., a business of Emerson Process Management.

*The contents of this publication are presented for informational purposes only, and while every effort has been made to ensure their accuracy, they are not to be construed as warranties or guarantees, express or implied, regarding the products or services described herein or their use or applicability. We reserve the right to modify or improve the designs or specifications of such products at any time without notice.*

Emerson Process Management does not assume responsibility for the selection, use or maintenance of any product. Responsibility for proper selection, use and maintenance of any Emerson Process Management product remains solely with the purchaser.